

Ripple Control Receiver SRcompact

The SRcompact is a state-of-the-art ripple control receiver of the newest generation for DIN rail mounting. With its two relays (16 A change-over contact) the SRcompact is ideal for all applications where mounting space is limited. The SRcompact is also the best choice when old receivers need to be replaced.

Features

- 2 relays 230 V, 16 A change-over contacts
- Indication of relay switch positions via LED
- Optical interface in accordance with IEC 62056-21 for parameterization, ripple control signal analysis and protocol evaluation
- DIN-rail mounting in accordance with DIN EN 60715 possible
- Compatible with all telegram systems commonly used (incl. DIN 43861-301)
- Swistra functionalities (option)
- Underfrequency detection
- Reaction on loss and return of power individually programmable
- Time Program Functions
- Network wide clock synchronisation



Technology

All Swistec ripple control receivers use state-of-the-art, recently developed filter algorithms capable of reliably processing ripple control signals with operating voltages below 0.3% U_n – a result of state-of-the-art processor technology combining high CPU power with little power consumption.

Time Program Functions

- Internal clock (remotely synchronized) for autonomous operation of up to 8 work schedules with 15 switching times each
- Free assignment of work schedules to the relays
- Real-time clock with super-cap (option), voltage interruptions can be bridged for a minimum of 48 hours

Programming

The programming is done via the standard optical interface (acc. to IEC 62056-21). The programming application is running on PCs, laptops or tablets under Windows XP or Windows 7.

Logging

Each received ripple control signal is logged and can be traced using an attached PC or laptop. This feature allows easier trouble shooting in case of any dysfunction of the device that is controlled by the SRcompact.

Technical Data

Right of any modification is reserved / Release 2.0

Power supply:	<ul style="list-style-type: none"> Mains voltage Frequency of mains voltage Power consumption Surge voltage resistance Terminal sizes 	230 VAC (-20% ... +15%) 50 Hz (-2% ... +1%) < 1 W / 10 VA cap. 8 kV 1.2/50 μ s accord. IEC 60060-1 Supply and relays 1 x 2.5 mm ² (AWG 22-12)
Filter data:	<ul style="list-style-type: none"> Operating frequency Operating voltage Non-operating voltage Maximum control voltage Swistra functions 	110 – 2000 Hz / programmable $U_f \geq 0.3\% U_n$ und $U_f > U_{nf}$ $U_{nf} \geq 0.1\% U_n$ 8-15 times U_f (depending on frequency) Available, option
Output data:	<ul style="list-style-type: none"> Number of relays Number of outputs Nominal switching voltage U_c Nominal switching current I_c Optical indication 	2, bistable 1 change-over contact each, free of potential 250 V, 50 Hz 16 A, $\cos \phi = 1$ LED
Real time clock:	<ul style="list-style-type: none"> Accuracy Power reserve (option) 	$\pm 20 \times 10^{-6}$ > 48 h, SuperCap optional
Resistance to climate conditions:	<ul style="list-style-type: none"> Operating temperature Storage temperature 	-20 ... +60°C -30 ... +60°C
Case:	<ul style="list-style-type: none"> Size 	H = 90 mm, W = 35 mm, D = 61 mm
Mounting:	<ul style="list-style-type: none"> Type of mounting 	DIN rail or wall mounting

Circuit diagram

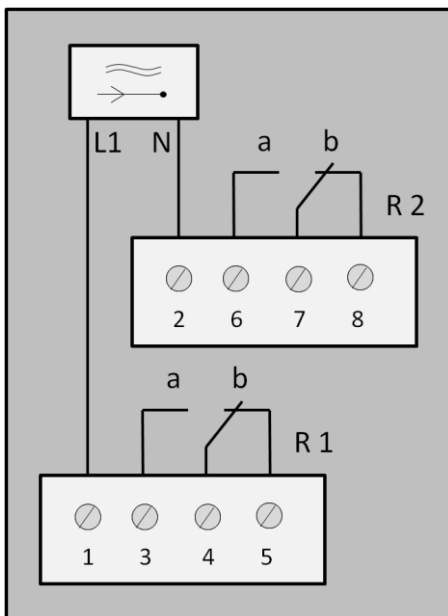

Intelligent Energy Management Systems

Ripple Control | Smart Solutions | Transformers

Swistec Systems AG

Allmendstrasse 30 · PO Box 182 · CH-8320 Fehraltorf

Phone +41 43 355 70 50 · Fax +41 43 355 70 51

info@swistec.ch · www.swistec.ch